

# ANW SERIES

ANW35 / 41 / 50  
ANW3500 / 4100 / 5000 (for North America)



ANW35 / 3500  
ANW41 / 4100

ANW35 / 3500



## Front and back machining on one machine

This dual spindle, dual turret CNC lathe integrates and streamlines your machining processes. The standard-equipped swing arm robot provides flexibility in automating your manufacturing system. By using the Fuji pass through concept, line efficiency is improved.



The above photo includes options.

### For a safe and clean environment

#### Vertical bed for effective chip disposal

The AN series features a vertical column with the cutting point directly above the chip disposal port at the bottom of the cutting area. Combined with Fuji's hinge-type chip conveyor (standard equipment) chips are cleared quickly and thoroughly from the cutting area.

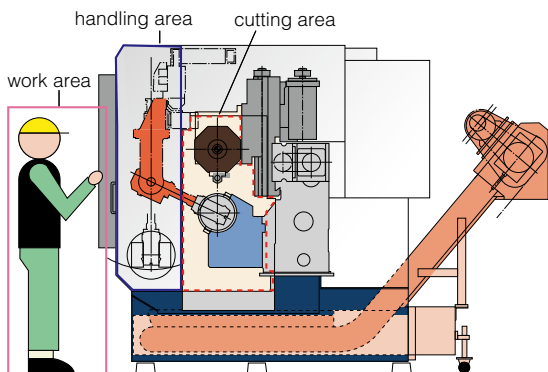
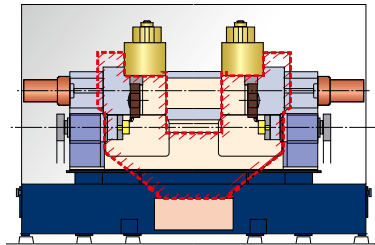

### Rough and finish cutting

Dual opposed spindles are mounted on the rock-solid column designed through CAE structural analysis. Light and heavy machining is possible simultaneously on both spindles.

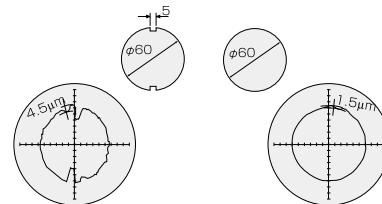
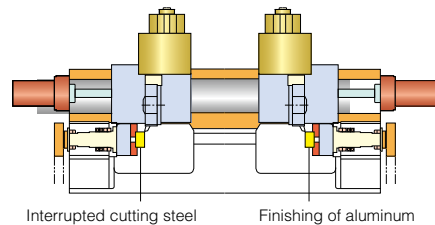

ANW35 / ANW3500

	Interrupted cutting steel	Finishing of aluminum
Spindle speed	825R.P.M	1,100R.P.M
Feed	0.1mm/rev	0.03mm/rev
Depth of cut	2mm/side	0.1mm/side
Insert	Cermet	Diamond compax
material	C45 (DIN)	Aluminum

## ANW series line up

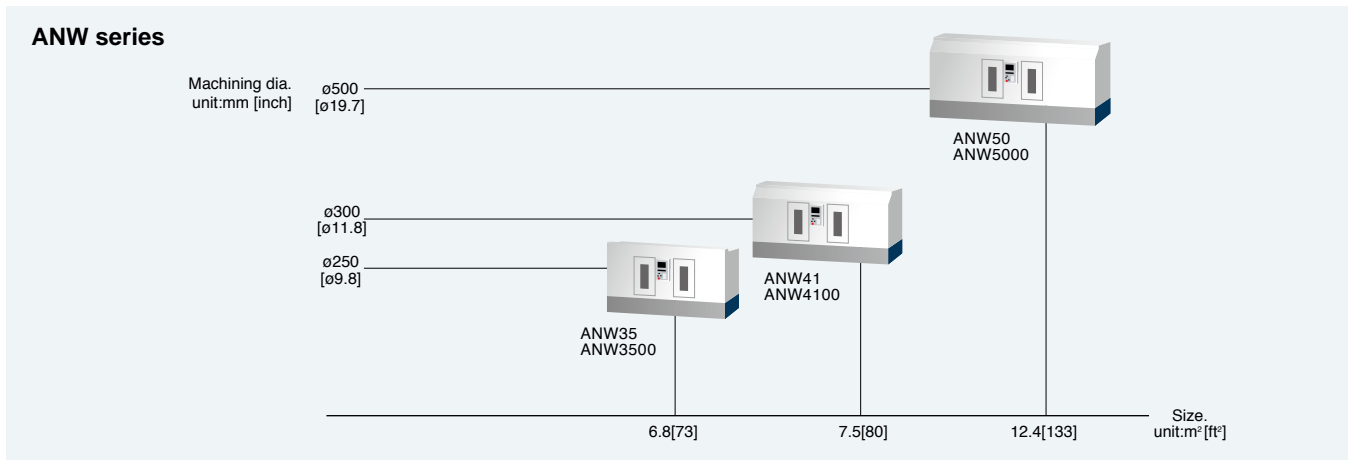

## Specifications for ANW series

### Machine specifications

		ANW35/3500	ANW41/4100	ANW50/5000
Recommended work size	mm[inch]	250 X 110 [9.8 X 4.3]	300 X 120 [11.8 X 4.7]	500 X 250 [19.7 X 9.8]
Spindle dia	mm[inch]	100 [3.9]	120 [4.7]	150 [5.9]
Spindle nose		A2-6	A2-8	A2-11
Spindle bore	mm[inch]	56 [2.2]	67 [2.6]	67 [2.6]
Spindle speed	min-1	Max. 3500	Max. 3000	Max. 2500
Spindle motor	kw[hp]	15/18.5 [20/25]	18.5/22 [25/30]	37/45 [50/60]
Number of tool stations		8+8	12+12	10+10
Turret index time	sec	0.4	1.2	1.0
Turret mechanism		Cam	Two piece coupling	Two piece coupling
Chuck size	inch	8(10)	10	15
CNC control		FANUC 0i-TD	FANUC 0i-TD	FANUC 0i-TD
Slide stroke	X-axis mm[inch]	225 [8.86]	265 [10.43]	345 [13.58]
	Z-axis mm[inch]	405 [15.94]	455 [17.91]	930 [36.61]
Feed motor	X-axis kw[hp]	3.0 [4.0]	4.0 [5.4]	4.0 [5.4]
	Z-axis kw[hp]	3.0 [4.0]	4.0 [5.4]	4.0 [5.4]

### Robot Specifications

		L292-L	L292-B1 option : L292-J	L292-G
Carrying capacity	kg [ lb. ]	7+7 [15+15]	10+10 [22+22] option: 30 [66]	40 [88]
Robot controller		MAX SP1	MAX SP1	MAX SP1

### Machine Size

		3490 X 1955 [11'5" X 6'5"]	3570 X 2105 [11'9" X 6'11"]	4700 X 2645 [15'5" X 8'8"]
Footprint	mm X mm [ feet, inch X feet, inch ]			
Machine height	mm [ feet, inch ]	2310 [7'7"]	2420 [7'11"]	2980 [9'9"]
Machine weight	kg [ lb. ]	8500 [18700]	9000 [19800]	12000 [26400]

### Machine specifications with live tool

		ANW35/3500	ANW41/4100
Rotary speed	min-1	3000	5000
Output	kw[hp]	3.0 [4.0]	2.2/3.7 [3/5]
Holder size	mm	1-16	1-20
Number of tool		8	12

### Machine specifications with tailstock

		ANW35/3500
Max.work length	mm[inch]	250 [9.8]
Center built-in type		MT.4
Quill stroke	mm[inch]	130 [5.1]
Quill dia	mm[inch]	100 [3.9]

Specifications are subject to change without notice.